

## Metis MS and MI "Self Contained" Pyrometer Series

Pyrometer Series *Metis MS* with silicon and *Metis MI* with indium gallium arsenide detector operate at the near end of the infrared spectrum. They are an excellent choice for measurement of ferrous and non-ferrous metals above 120°C because the emissivity of un-oxidized metal surfaces is higher at shorter wavelengths. Other major advantages are the lower sensitivity for changes in emissivity at shorter wavelengths, the small spot sizes, the fast exposition time and the digital signal processing which allow the pyrometer to operate over very wide temperature ranges. This makes these units preferable for other applications, too. Optical and electronic parts are housed in rugged IP65 extruded aluminium casting to operate in harsh industrial environments.

**Chart 1: Temperature Range and Spectral Response**

Model	MS09	MI16	New MI18
<b>Wavelength</b>	0.9 µm	1.6 µm	1.8 µm
<b>Temperature Range</b>	550 – 1400°C	250 – 1000°C	120 – 550°C 160 – 800°C
	600 – 1600°C	300 – 1300°C	
	650 – 1800°C	350 – 1800°C	
	750 – 2500°C	500 – 2500°C	
	1000 – 3300°C		



**Lenses and Fibre-Optic Cable:** The infrared energy radiated by the target is centered either directly on the detector (standard version) or on one end of a fibre optic cable by focusable lenses. This feature offers the possibility to measure a small spot (focused) or the average of a bigger spot (out of focus). Lenses are made of BK7, an optical glass which is highly transparent in the spectral region of *Metis MS* and *MI*. If additional windows are necessary, they must offer similar optical characteristics. Fibre-optic versions are supplied with 2.5 m long single mode fibres, diameter 0.2 mm, (0.4 mm MI18 only). Longer cables are available on request.

**Chart 2: Focusable Lenses of Metis Standard Version**

Lens	Distance	Spot Size Diameter	
		MS09 / MI16	MI16*) / MI18
OM09-A0	130 mm	0.35 mm	0.7 mm
	160 mm	0.50 mm	1.0 mm
	200 mm	0.70 mm	1.4 mm
OM09-B0	190 mm	0.50 mm	1.0 mm
	300 mm	0.80 mm	1.6 mm
	420 mm	1.30 mm	2.6 mm
OM09-C0	340 mm	0.90 mm	1.8 mm
	2000 mm	6.50 mm	13 mm
	4000 mm	15 mm	30 mm

**Chart 3: Focusable Lenses of Metis Fibre-Optic Version**

Lens	Distance	Spot Size Diameter	
		MS09 / MI16	MI16*) / MI18
OL25-G0	75 mm	0.50 mm	0.7 mm
	130 mm	0.65 mm	0.85 mm
	180 mm	0.70 mm	1.0 mm
OL25-H0	200 mm	0.75 mm	1.4 mm
	2000 mm	9 mm	17 mm
	4500 mm	22 mm	40 mm

\*) Temperature range 250 – 1000°C only

The detector is sensitive to infrared radiation in an area called **cone of vision**. For the spot size diameter Ø of it at shortest, medium and widest distances, if focused, pls. see **Chart 2 and 3**. For full scale temperatures up to 1400°C the cone of vision diameter in front of the lens is about 16 mm and about 8 mm for full scale temperatures above. This area has to be kept free from any intervening objects. The spot size diameter for distances not given in the chart can be calculated by interpolation.

**Chart 4: Miniatur Focusable Lens available with Fibre-Optic Version**

Lens	Distance	Spot Size Diameter	
		MS09 / MI16	MI16*) / MI18
OL12-A0	100 mm	1.0 mm	2.0 mm
	350 mm	3.7 mm	7.4 mm
	600 mm	7.0 mm	14 mm

A small 12 mm diameter focusable lens with an aperture (cone of vision) diameter of 7 mm in front of the lens is available for applications where a miniature reimaging lens is necessary. For diameters at the focal distance please see Chart 4.

\*) Temperature range 250 – 1000°C only

**Optical Alignment:** *Metis MS* and *MI* Standard Pyrometers are available with 3 different solutions for aiming the sensor onto the target. Number one and most popular method is the built in laser pointer which is also helpful for focusing. Number two is a sight through optics version with reticle-defined target which is advantageous for applications where aiming onto hot, incandescent targets is needed. The viewing telescope of these units, with full scale temperatures above 1800°C, is equipped with a dimmable sight attenuation filter to protect the eye. And finally, the third solution is a built in b/w video camera for all applications where neither the laser nor the sight through version can be used. This feature offers also possibilities for remote controlling of the heating process in dangerous environments. The fibre-optic version of *Metis* can be equipped with laser pointer only.

**Temperature Output Signals:** *Metis* Pyrometers offer a variety of analog and digital output signals for indication, recording, archiving and controlling of measured process temperatures. The isolated analog output is switch able from 0 to 4 to 20 mA. Zero- and full-scale temperatures are adjustable to cover any portion of the instrument's available temperature span to a minimum of 50°C.

There is a choice of 3 digital communication interfaces: **RS 232** or **RS 485** max. 57.6 kBd or **Profibus**.

**PID Control:** The pyrometer can be equipped with PID control output signal instead of the analog temperature output signal 0 – or 4 – 20 mA. The control features and functions can be operated manually by PC or automatically by digital commands. The self-optimizing feature automatically determines the P, I and D control parameters. If PID option is chosen, the temperature information will be available from the pyrometer only via digital interface.

**Signal Filtering:** For measuring and holding of the highest instantaneous temperature value a **peak picker** (maximum value storage) is installed to compensate interruptions or attenuations in radiation caused by bursts of steam, smoke or dust. It can be either reset automatically or manually by an external contact closure or periodically by user preset clear time. In this last case the highest temperature will be held in a dual storage and will be reset in only one of the two storages after preset clear time to avoid a decrease of the temperature output, should a short cold period appear just at the reset moment. The **exposition time** is the length of time it takes for the output signal to reach 90% of a step change in measured temperature. It can be used to filter out rapid variations in temperature and achieve a “more quiet” signal for control or display purposes.

**Software:** The **PSCWin Software** is available for automatic or manual set up of the pyrometer, for recording and for saving of graphical or table files. At the same time these files can be used for quality assurance purposes because the parameter settings are recorded, too. Minimum computer requirements are: 500 MHz clock frequency and Windows 95, 98, ME or XP operating system.

**Customized Solutions:** In order to measure temperatures at the strip bottom in hot rolling mills, or slab temperatures inside the cooling chamber of continuous casters, special rugged sensing heads in stainless steel housings with external electronic boards have proven themselves very well for this purpose.

### Additional Specifications

Measurement Uncertainty MS09/MI16 Series:	fullscale temperatures < 1500°C: 0.3% of measured value in °C + 1°C fullscale temperatures < 2500°C: 0.5% of measured value in °C
Measurement Uncertainty MI18:	0.4% of measured value in °C + 1°C or 2°C, whichever is greater
Repeatability MS09/MI16 Ser.:	0.1% of measured value in °C + 1°C
Repeatability MI18 Series:	0.2% of measured value in °C + 1°C or 1,6°C, whichever is greater
Response Time $t_{90}$ :	1 ms with dynamic adaptation at low signal levels, adjustable up to 10 s
Analog Output Signal:	0 or 4 – 20 mA selectable, 500 $\Omega$ max. load
Digital Interface:	either RS 232 or RS 485 max. 57,6 kBd (standard supply), Profibus (optional)
Temperature Resolution:	analog < 0.1% of adjusted temperature range, digital 0.1°C
Ambient Temperature Range:	<b>Pyrometer:</b> operation -10 – 70°C, storage -20 – 70°C, <b>Fibre Optic Cable and Lens:</b> 0-250°C
Power Supply:	24 V AC/DC (12 – 30 V AC/DC), AC: 48 – 62 Hz, max. 2 VA
Isolation:	power supply, analog and digital output are galvanically isol. against each other and against housing
Housing and Rating:	extruded aluminium profile, IP 65 per DIN 40 050
Weight:	500 g
CE Label:	according to EU directives for electromagnetic immunity
Laser Pointer:	(optional) 650 nm, < 1 mW, class II per IEC 60825-1-3-4
<b>Camera Modul:</b>	PAL or NTSC
Video Signal:	isolated BAS signal about 1 V <sub>SS</sub> at 75 $\Omega$ , CCIR standard, 50 Hz
Resolution:	black/white 628 x 582 pixel
Field of View:	about 14% x 10% of focused distance
Signal Port:	Cinch connector with SCART adapter connected to cable assembly (accessory)
Date, Time:	real time clock with 5 year buffer
Image Overlays:	reticle, model no. or text of your choice, max. 12 characters, time or date, temperature and emissivity

### Dimensions: Metis MS and MI with Focusable Lens and Swivel Base HA20

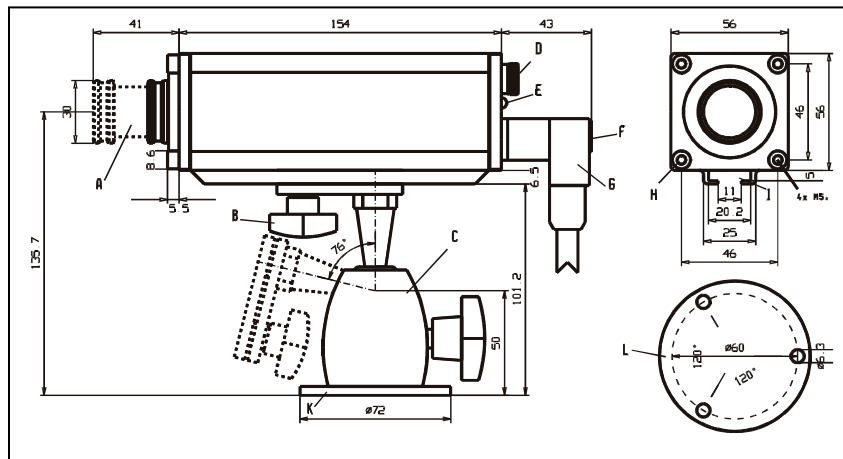

- A: Focusable Lens
- B: Fast-Mount Screw
- C: Swivel Mounting Base
- D: Eye Piece (for models with sight-through optics only)
- E: Operation LED
- F: Laser Push Button
- G: 12-pin Connector
- H: Front-Mount Threads
- I: Mounting Rail
- K: Swivel Base Mounting Flange
- L: Base View of item K with Mounting Holes

### Special Accessories available with Metis MS and Metis MI only:

Description	Model
Camera Cable Assembly for Metis MS and MI, length 5 m	AK50-05
Air Purge for Fibre-Optic Lens OL12	BL13-00
Air Purge for Fibre-Optic Lens OL25	BL14-00
Adjustable Mounting Bracket for Fibre-Optic Lens OL12	HA13-00
Adjustable Mounting Bracket for Fibre-Optic Lens OL25	HA14-00
2.5 m Spare Fibre-Optic Cable Metis MS09 and MI16, $\varnothing$ 0.2 mm	LL02-02
2.5 m Spare Fibre-Optic Cable Metis MI18, $\varnothing$ 0.4 mm	LL04-02
External Profibus Converter with 3 m Interconnecting Cable	PB10-03

**Notice:** Standard Accessories for mounting and protecting of Metis Pyrometer series see back page of Metis brochure

**Process Sensors Corporation**  
 113 Cedar Street  
 Milford, MA 01757 USA  
 Tel: (508) 473-9901  
 Fax: (508) 473-0715  
[IRtemp@processsensors.com](mailto:IRtemp@processsensors.com)  
[www.processsensors.com](http://www.processsensors.com)